



 **MARSHAL®**

CONDENSING UNIT

AIR CONDITIONERS

Capacity 6-25TR

3ODH - 50Hz

R410A



MAKING LIFE COOL

TABLE OF CONTENTS

INTRODUCTION.....	3
SALIENT FEATURES.....	4
ENGINEERING SPECIFICATIONS	5
CONDENSING UNITS PERFORMANCE DATA	6
ELECTRICAL DATA	7
GENERAL ARRANGEMENT DRAWINGS	8
WIRING DIAGRAM	11

INTRODUCTION

Condensing Units have been developed & produced to provide not only the ultimate indoor comfort, but also to guarantee long & trouble free operations.

Here lies the reason for the choice of only the highest quality components and design strategit to meet the most important objective such as:

- EFFICIENCY
- RELIABILITY
- FLEXIBILITY
- EASY INSTALLABILITY
- SERVICEABILITY
- AFFORDABILITY

3ODH



FEATURES

Standard Features

- Refrigerant : R410A.
- Power Supply: 380-415V/3PH/50Hz.
- Factory Wired with Single Point Power Input.
- Scroll Compressor.
- High Pressure & Low Pressure Safety Switches.
- Power Controller, High/Low Voltage, Phase Loss/Reversal Protection.
- All units are provided with ON-Delay timers for Anti-short cycling.
- Internal Motor Protection for 3Ø Outdoor Motors.
- All Units are designed to operate with 24V Universal Thermostat.
- Condenser Fans are Propeller type Direct Driven, draw through Vertical Discharge with fan guard mounted to the Panel.
- Condenser Coils are with Copper tubes and Aluminum fins.
- Weather resistant steel cabinet, qualified for 1000 Hours of Salt Spray test.

Optional Features

- Copper Fins for Condenser coil.
- Heresite Coated Condenser Coil.
- Overload External Protection for Compressor & Condenser Fan.
- Compressor Alternating Switch.
- Hour Run Meter.
- Fan Cycling Switch.
- Low Ambient kit.
- Rotolock Compressor.
- Circuit breaker (MCB) for Compressor, Condenser Motor.
- Pump Down System.
- Hot Gas Bypass (with Solenoid).
- Pressure Gauges.
- PCB Controller.
- Advanced Microprocessor Controller.
- Adjustable Voltage Monitor.
- Adjustable Pressure Switch.
- Volt free Contacts for Compressor ON/OFF/TRIP Status.
- Fire Alarm Interlock.
- Crankcase Heater for Compressor.
- Sight Glass.

CONDENSING UNITS - R410A PRODUCT DATA BOOK

ENGINEERING SPECIFICATIONS

Outdoor

TECHNICAL SPECIFICATIONS					
MODEL / UNIT		30DH072	30DH090	30DH120	30DH150
RATED CAPACITY *	Cooling Btu/Hr	70,500	88,700	125,300	160,300
RATED POWER CONSUMPTION *	Watts	5,000	6,700	8,600	11,500
EER *		14.10	13.24	14.57	13.94
RATED CAPACITY **	Cooling Btu/Hr	59,500	73,900	104,500	106,200
RATED POWER CONSUMPTION **	Watts	6,200	8,600	11,000	15,000
EER **		9.60	8.59	9.50	7.08
REFRIGERATION SYSTEM	Type	R-410A			
	Circuit	Single	Single	Dual	Dual
POWER SUPPLY	V / Ph / Hz	380-415V / 3Ph / 50Hz			
COMPRESSOR	Type	Scroll	Scroll	Scroll	Scroll
	Quantity Nos.	1	1	2	2
CONDENSER FAN	Type	Propeller fan drive			
	Size-Dia x Width(Inch)	26"	22"	26"	26"
	Quantity Nos.	1	2	2	2
CONDENSER MOTOR	Motor H.P	0.75	1/3	0.75	0.75
	Quantity Nos.	1	2	2	2
	IP	IP20	IP44	IP20	IP20
CONDENSER COIL	Type	Corrugated Fin & Inner grooved Tube			
	Tube - Dia - Row - FPI	3/8"-3-15	3/8"-3-15	3/8"-2-14	3/8"-3-15
	No. of Coils	2	2	2	2
REFRIGERANT LINES	Suction valve conn. (Inch)	7/8	1 1/8	7/8	7/8
	Liquid Valve conn. (Inch)	1/2	1/2	1/2	1/2
UNIT DIMENSIONS	W x D x H (mm)	900 x 975 x 940	918 x 1590 x 945	1157 x 1950 x 1203	1157 x 1950 x 1203

MODEL / UNIT		30DH180	30DH216	30DH240	30DH300
RATED CAPACITY *	Cooling Btu/Hr	188,300	217,600	252,800	284,900
RATED POWER CONSUMPTION *	Watts	12,300	14,800	17,600	18,700
EER *		15.31	14.70	14.36	15.24
RATED CAPACITY **	Cooling Btu/Hr	163,600	183,300	212,700	246,200
RATED POWER CONSUMPTION **	Watts	16,700	19,100	22,800	26,200
EER **		9.80	9.60	9.33	9.40
REFRIGERATION SYSTEM	Type	R-410A			
	Circuit	Dual	Dual	Dual	Dual
POWER SUPPLY	V / Ph / Hz	380-415V / 3Ph / 50Hz			
COMPRESSOR	Type	Scroll	Scroll	Scroll	Scroll
	Quantity Nos.	2	2	2	2
CONDENSER FAN	Type	Propeller fan drive			
	Size-Dia x Width(Inch)	26"	26"	26"	26"
	Quantity Nos.	2	4	4	4
CONDENSER MOTOR	Motor H.P	0.75	0.50	0.50	0.50
	Quantity Nos.	2	4	4	4
	IP	IP20	IP20	IP20	IP20
CONDENSER COIL	Type	Corrugated Fin & Inner grooved Tube			
	Tube - Dia - Row - FPI	3/8"-4-14	3/8"-3-14	3/8"-3-14	3/8"-4-14
	No. of Coils	2	2	2	2
REFRIGERANT LINES	Suction valve conn. (Inch)	1 1/8	1 3/8	1 3/8	1 3/8
	Liquid Valve conn. (Inch)	5/8	7/8	7/8	7/8
UNIT DIMENSIONS	W x D x H (mm)	1157 x 2050 x 1240	2150 x 2000 x 1471	2150 x 2000 x 1471	2150 x 2000 x 1471

NOTES:

*Cooling Capacity & EER are rated @ 50°F SST and 95°F DBT outdoor.

** Cooling Capacity & EER are rated @ 50°F SST and 114.8°F DBT outdoor .

As a result of continuous research and development, the above specifications are subject to changes without notice.

CONDENSING UNITS - R410A PRODUCT DATA BOOK

CONDENSING UNITS PERFORMANCE DATA

072K - 300K

MODEL:		30DH072GC1B													
SST (°F)		AMBIENT AIR TEMPRATURE (°F)													
		85.0		95.0		105.0		114.8		118.4		120.0		125.0	
		MBH	KW	MBH	KW	MBH	KW	MBH	KW	MBH	KW	MBH	KW	MBH	KW
35.00		57.8	4.4	54.2	4.8	50.5	5.4	45.5	6.0	44.1	6.3	42.6	6.5	41.3	6.7
40.00		63.2	4.4	59.4	4.9	55.3	5.5	49.8	6.1	48.3	6.3	46.7	6.6	45.3	6.8
45.00		69.0	4.5	64.8	5.0	60.5	5.5	54.6	6.2	53.0	6.4	51.2	6.7	49.7	6.9
50.00		75.0	4.6	70.5	5.0	65.9	5.6	59.5	6.2	57.8	6.5	55.9	6.7	54.2	6.9
55.00		81.3	4.6	76.6	5.1	71.6	5.7	64.7	6.3	62.9	6.5	60.9	6.8	59.2	7.0

MODEL:		30DH090GC1B													
SST (°F)		AMBIENT AIR TEMPRATURE (°F)													
		85.0		95.0		105.0		114.8		118.4		120.0		125.0	
		MBH	KW	MBH	KW	MBH	KW	MBH	KW	MBH	KW	MBH	KW	MBH	KW
35.00		73.3	5.6	68.7	6.3	63.7	7.1	58.5	7.9	56.6	8.2	54.4	8.6	52.6	8.9
40.00		79.9	5.7	75.0	6.4	69.7	7.2	64.1	8.0	62.1	8.3	59.8	8.7	57.7	9.0
45.00		86.9	5.8	81.7	6.5	76.0	7.3	70.0	8.1	67.8	8.4	65.4	8.8	63.3	9.1
50.00		94.2	6.0	88.7	6.7	82.5	7.4	76.2	8.3	73.9	8.6	71.3	8.9	69.1	9.2
55.00		101.9	6.1	95.9	6.8	89.4	7.6	82.6	8.4	80.1	8.7	77.3	9.1	75.0	9.4

MODEL:		30DH120GC2B													
SST (°F)		AMBIENT AIR TEMPRATURE (°F)													
		85.0		95.0		105.0		114.8		118.4		120.0		125.0	
		MBH	KW	MBH	KW	MBH	KW	MBH	KW	MBH	KW	MBH	KW	MBH	KW
35.00		102.1	7.7	95.7	8.6	88.4	9.5	75.8	9.5	73.1	9.8	70.2	10.0	67.7	10.2
40.00		111.6	7.5	105.2	8.6	98.5	9.8	86.3	10.1	84.0	10.5	81.7	11.0	79.8	11.4
45.00		121.7	7.5	115.1	8.6	108.7	9.9	96.6	10.5	94.6	11.0	92.8	11.6	91.3	12.1
50.00		132.2	7.5	125.3	8.6	118.8	9.9	106.2	10.5	104.5	11.0	102.8	11.6	101.5	12.2
55.00		142.9	7.6	135.3	8.6	128.3	9.7	114.8	10.1	113.0	10.6	111.1	11.1	109.9	11.5

MODEL:		30DH150GC2B													
SST (°F)		AMBIENT AIR TEMPRATURE (°F)													
		85.0		95.0		105.0		114.8		118.4		120.0		125.0	
		MBH	KW	MBH	KW	MBH	KW	MBH	KW	MBH	KW	MBH	KW	MBH	KW
35.00		132.0	9.5	123.4	10.7	114.5	12.1	103.5	14.2	100.1	14.8	96.6	15.5	93.6	16.1
40.00		144.1	9.8	135.0	11.0	125.4	12.4	113.6	14.5	110.0	15.1	106.2	15.8	102.9	16.3
45.00		156.9	10.0	147.3	11.2	137.0	12.6	124.4	14.7	120.5	15.3	116.5	16.0	113.0	16.6
50.00		170.6	10.3	160.3	11.5	149.3	12.9	135.8	15.0	131.8	15.6	127.4	16.3	123.7	16.9
55.00		185.0	10.6	174.0	11.8	162.4	13.2	147.9	15.3	143.6	15.9	138.9	16.6	135.0	17.1

MODEL:		30DH180GC2B													
SST (°F)		AMBIENT AIR TEMPRATURE (°F)													
		85.0		95.0		105.0		114.8		118.4		120.0		125.0	
		MBH	KW	MBH	KW	MBH	KW	MBH	KW	MBH	KW	MBH	KW	MBH	KW
35.00		155.4	10.4	145.9	11.5	135.5	13.0	125.7	16.0	121.4	16.7	116.7	17.5	112.5	18.3
40.00		169.7	10.6	159.3	11.8	148.1	13.2	137.7	16.2	133.1	16.9	128.1	17.7	123.6	18.4
45.00		184.6	10.8	173.4	12.0	161.4	13.4	150.3	16.4	145.5	17.1	140.1	17.9	135.5	18.6
50.00		200.4	11.1	188.3	12.3	175.4	13.7	163.6	16.7	158.5	17.4	152.7	18.2	147.8	18.8
55.00		216.7	11.4	203.8	12.6	189.9	14.0	177.4	17.0	171.9	17.7	165.8	18.4	160.6	19.1

MODEL:		30DH216GC2B													
SST (°F)		AMBIENT AIR TEMPRATURE (°F)													
		85.0		95.0		105.0		114.8		118.4		120.0		125.0	
		MBH	KW	MBH	KW	MBH	KW	MBH	KW	MBH	KW	MBH	KW	MBH	KW
35.00		179.2	12.6	167.9	14.2	155.5	16.1	139.5	18.5	134.7	19.3	129.6	20.2	125.2	21.0
40.00		195.5	12.8	183.6	14.4	170.5	16.2	153.3	18.7	148.2	19.5	142.8	20.4	138.1	21.2
45.00		212.7	13.0	200.2	14.6	186.3	16.4	167.9	18.8	162.6	19.6	156.6	20.5	151.8	21.3
50.00		230.8	13.3	217.6	14.8	202.9	16.6	183.3	19.1	177.5	19.8	171.3	20.7	166.0	21.5
55.00		249.8	13.6	235.8	15.1	220.3	16.9	199.3	19.3	193.3	20.1	186.7	20.9	181.1	21.7

MODEL:		30DH240GC2B													
SST (°F)		AMBIENT AIR TEMPRATURE (°F)													
		85.0		95.0		105.0		114.8		118.4		120.0		125.0	
		MBH	KW	MBH	KW	MBH	KW	MBH	KW	MBH	KW	MBH	KW	MBH	KW
35.00		209.6	14.8	195.9	16.7	180.9	18.9	163.0	22.0	157.2	22.9	150.8	24.0	145.4	24.9
40.00		228.6	15.1	213.9	17.0	197.9	19.2	178.8	22.2	172.6	23.2	165.8	24.3	160.1	25.2
45.00		248.6	15.4	232.9	17.2	215.8	19.4	195.3	22.5	188.8	23.5	181.7	24.5	175.5	25.5
50.00		269.7	15.7	252.8	17.6	234.6	19.7	212.7	22.8	205.7	23.8	198.1	24.8	191.6	25.8
55.00		291.8	16.1	273.7	17.9	254.1	20.1	230.8	23.1	223.4	24.1	215.3	25.2	208.4	26.1

MODEL:		30DH300GC2B													
SST (°F)		AMBIENT AIR TEMPRATURE (°F)													
		85.0		95.0		105.0		114.8		118.4		120.0		125.0	
		MBH	KW	MBH	KW	MBH	KW	MBH	KW	MBH	KW	MBH	KW	MBH	KW
35.00		235.0	15.7	220.4	17.6	204.2	19.7	189.4	25.1	182.9	26.1	175.7	27.2	169.6	28.2
40.00		256.6	16.1	240.8	17.9	223.2	20.0	207.3	25.4	200.2	26.5	192.5	27.6	185.9	28.6
45.00		279.4	16.4	262.2	18.3	243.4	20.4	226.2	25.8	218.6	26.8	210.3	28.0	203.2	28.9
50.00		303.4	16.9	284.9	18.7	264.5	20.8	246.2	26.2	238.0	27.2	229.1	28.3	221.5	29.3
55.00		328.7	17.4	308.8	19.1	286.8	21.2	267.2	26.6	258.5	27.6	248.9	28.8	240.7	29.7

Notes: • Power consumption is the total power consumption of compressor and condenser motor.

CONDENSING UNITS - R410A PRODUCT DATA BOOK

ELECTRICAL DATA

072K - 300K

OUTDOOR UNITS												
MODEL	POWER SUPPLY			COMPRESSOR				CONDENSER MOTOR			MCA	MOCP
	V/PH/Hz	MIN VOLT	MAX VOLT	TYPE	RLA	LRA	QTY	HP	FLA	QTY	AMPS	AMPS
3ODH072	380-415/3/50	342	456	SCR	9.8	101.0	1	0.75	5.7	1	18	25
3ODH090	380-415/3/50	342	456	SCR	14.3	128.0	1	1/3	2	2	22	35
3ODH120	380-415/3/50	342	456	SCR	9.5	67.1	2	0.75	5.7	2	33	40
3ODH150	380-415/3/50	342	456	SCR	11.7	101.0	2	0.75	5.7	2	38	50
3ODH180	380-415/3/50	342	456	SCR	14.3	128.0	2	0.75	5.7	2	44	60
3ODH216	380-415/3/50	342	456	SCR	16.6	118.0	2	0.50	3.0	4	50	65
3ODH240	380-415/3/50	342	456	SCR	18.3	118.0	2	0.50	3.0	4	54	70
3ODH300	380-415/3/50	342	456	SCR	20.8	20.8	2	0.50	3.0	4	60	80

NOTE:

FLA - Full Load Amps. **LRA** - Lock Rotor Amps. **RLA** - Running Load Amps. **MCA** - Minimum Circuit Amps.
MOCP - Maximum Over Current Protection.

GENERAL ARRANGEMENT DRAWINGS - OUTDOOR

072K

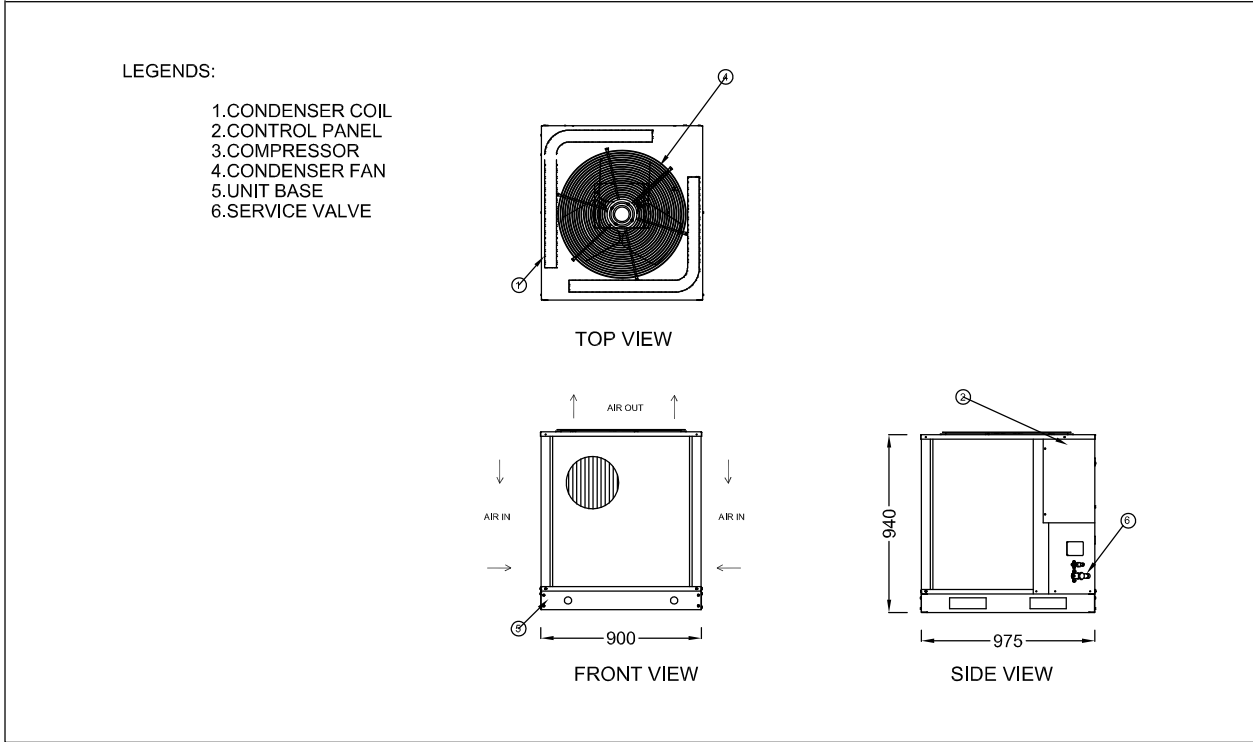

090K

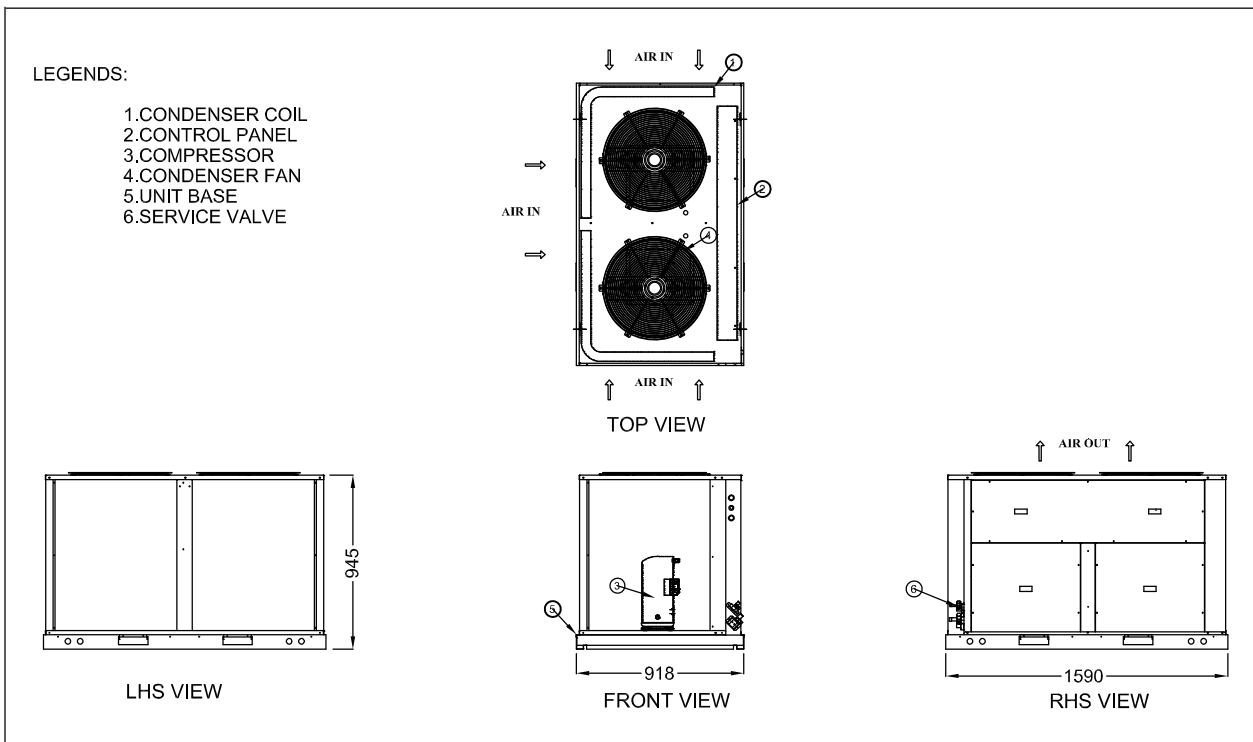

GENERAL ARRANGEMENT DRAWINGS - OUTDOOR

120K - 150K

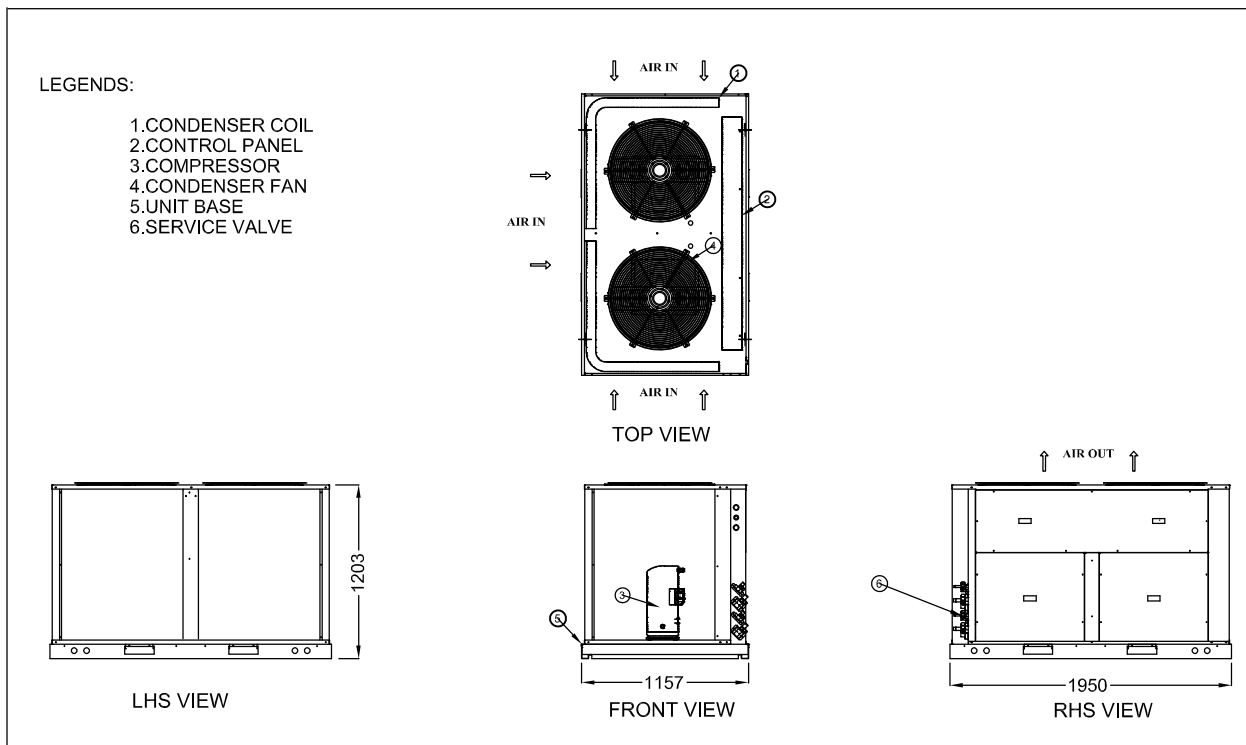

180K

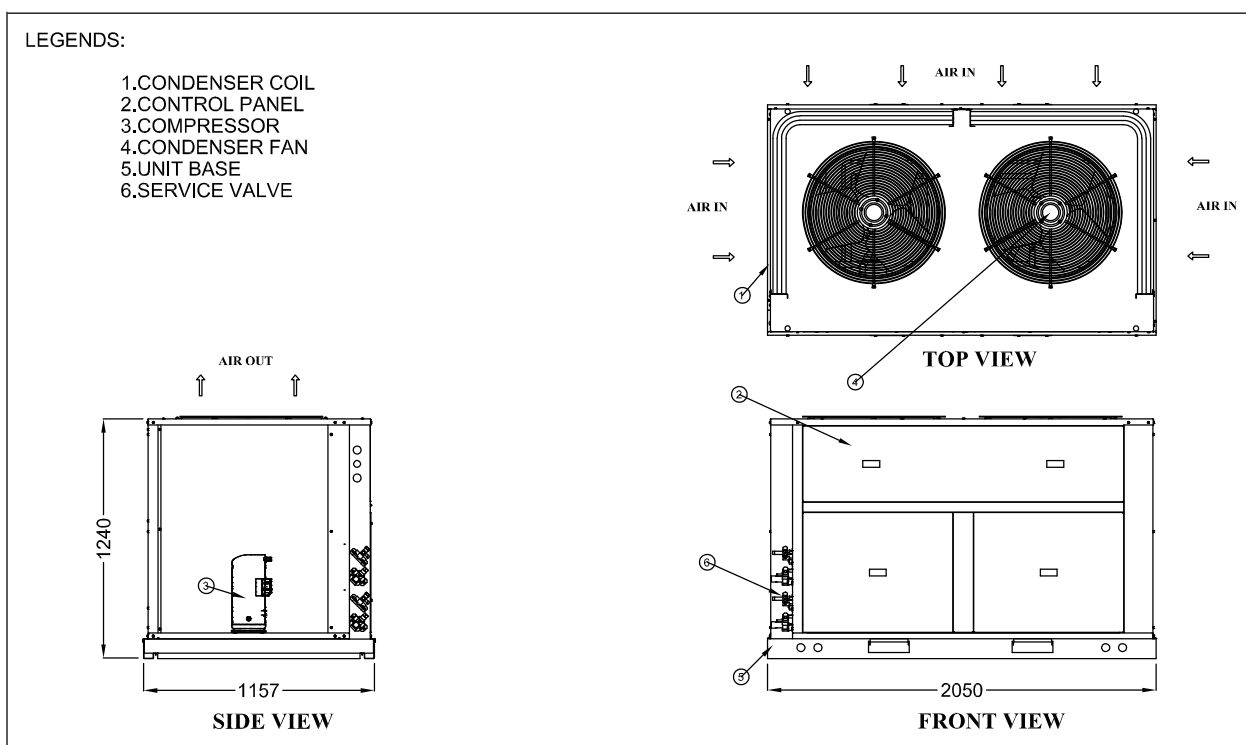

GENERAL ARRANGEMENT DRAWINGS - OUTDOOR

216K - 240K - 300K

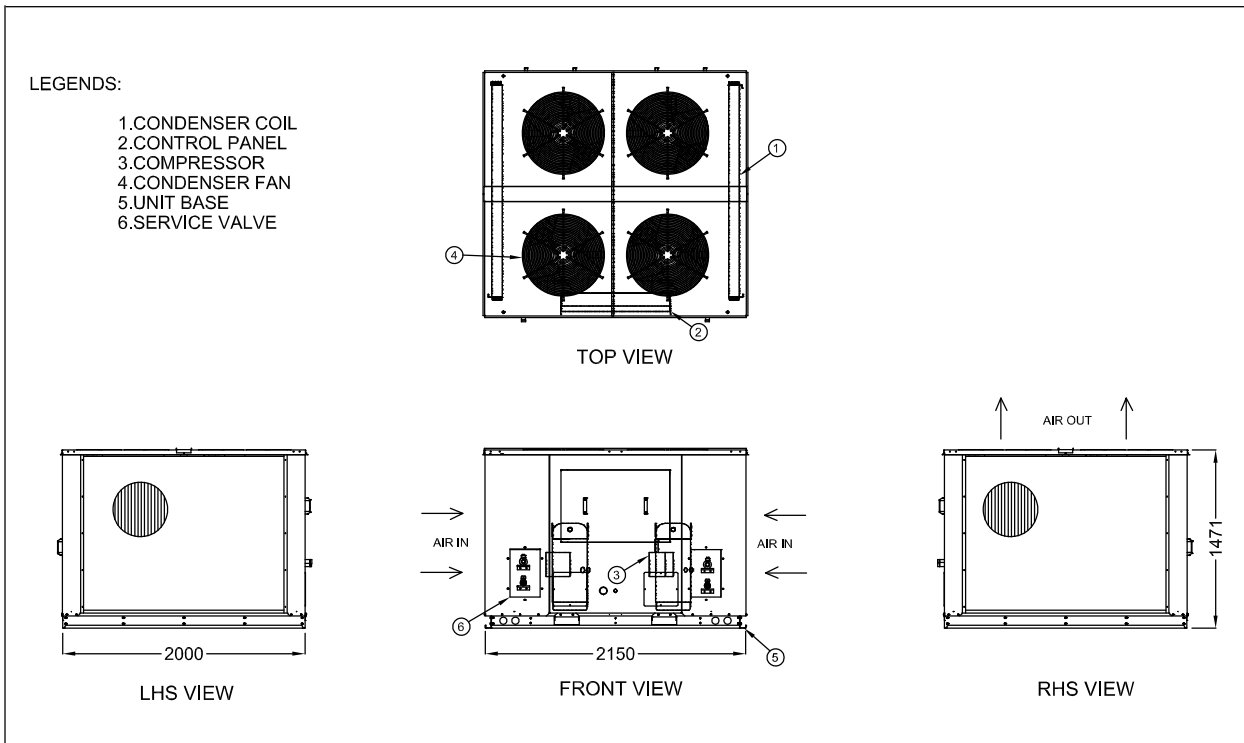

CONDENSING UNITS - R410A PRODUCT DATA BOOK

WIRING DIAGRAM - OUTDOOR

072K

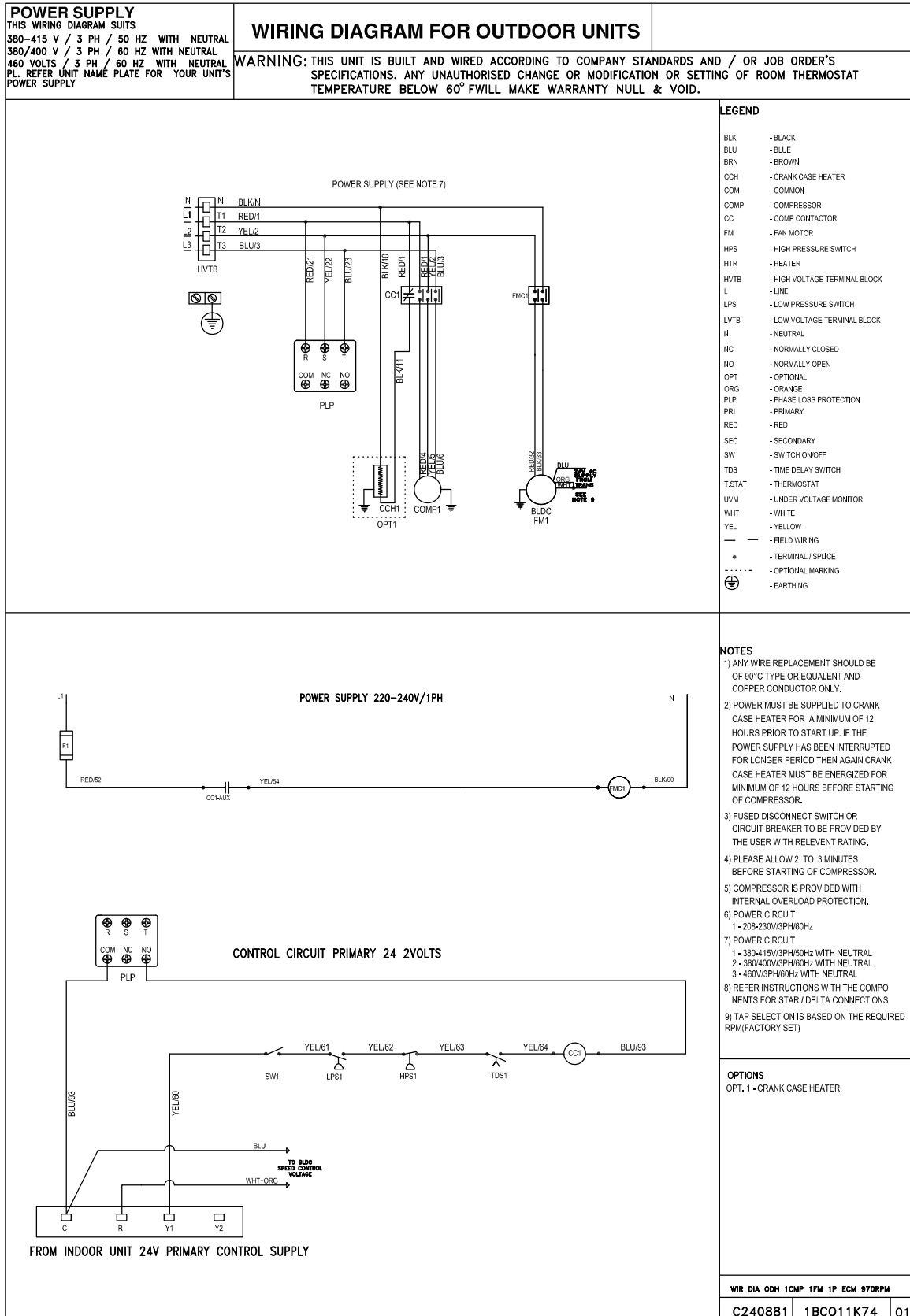

CONDENSING UNITS - R410A PRODUCT DATA BOOK

WIRING DIAGRAM - OUTDOOR

090K

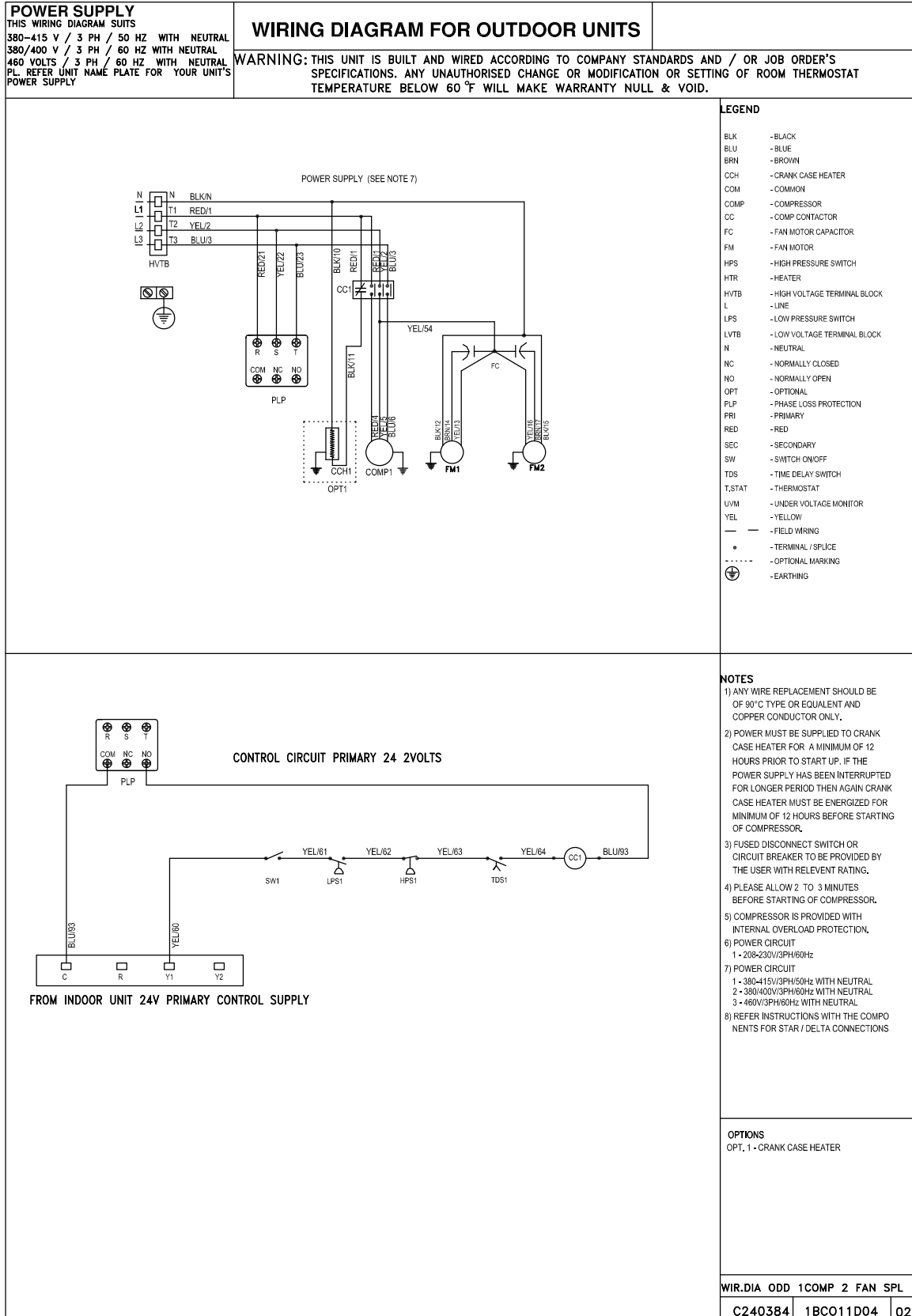

CONDENSING UNITS - R410A PRODUCT DATA BOOK

WIRING DIAGRAM - OUTDOOR

120K - 150K - 180K

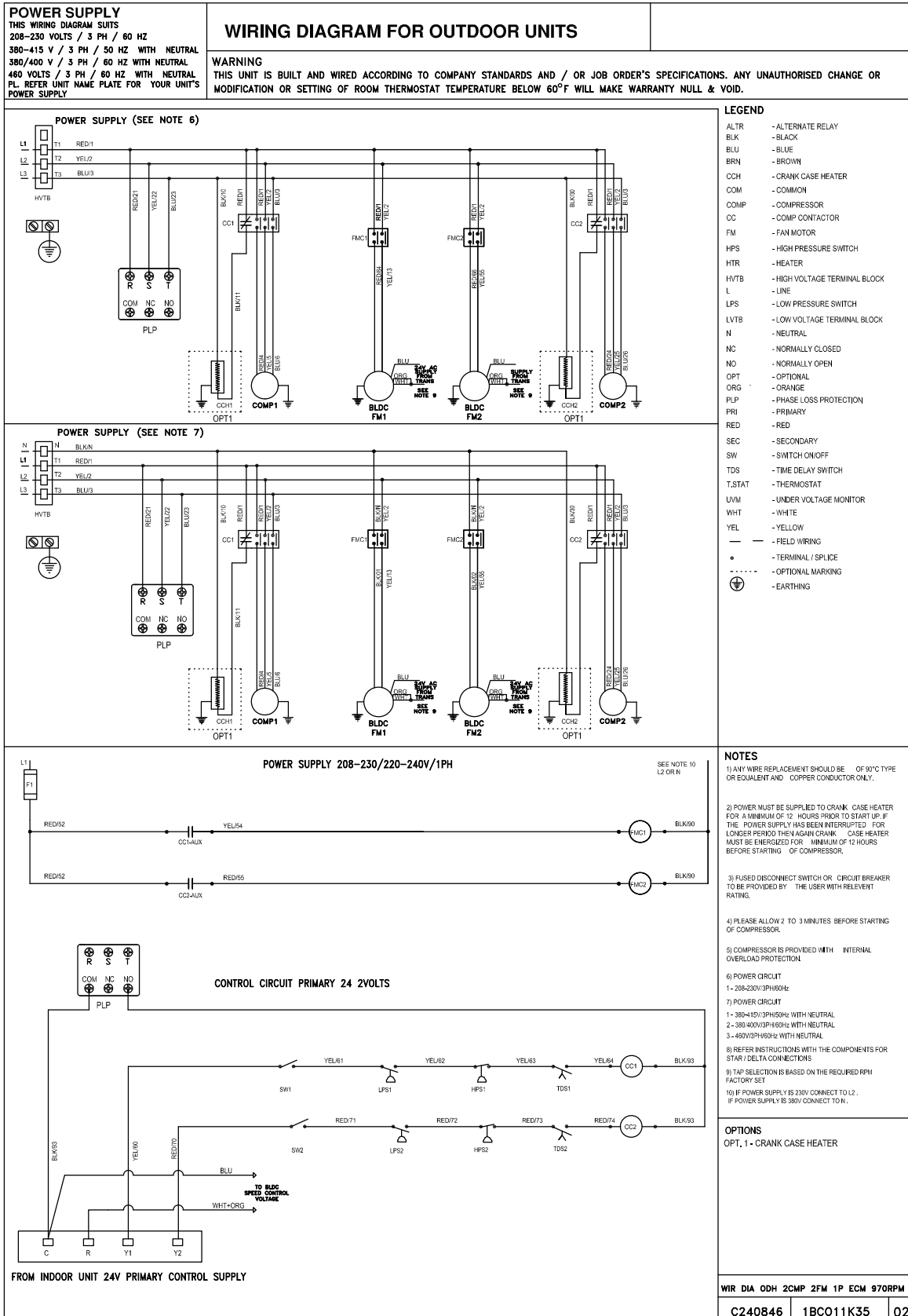

CONDENSING UNITS - R410A PRODUCT DATA BOOK

WIRING DIAGRAM - OUTDOOR

216K - 240K - 300K

<p>POWER SUPPLY THIS WIRING DIAGRAM SUITS 208-230 VOLTS / 3 PH / 60 HZ 380-415 V / 3 PH / 50 HZ WITH NEUTRAL 380-400 V / 3 PH / 60 HZ WITH NEUTRAL 480 VOLTS / 3 PH / 60 HZ WITH NEUTRAL PL REFER UNIT NAME PLATE FOR YOUR UNITS POWER SUPPLY</p>	<p style="text-align: center;">WIRING DIAGRAM FOR OUTDOOR UNITS</p> <p>WARNING THIS UNIT IS BUILT AND WIRED ACCORDING TO COMPANY STANDARDS AND / OR JOB ORDER'S SPECIFICATIONS. ANY UNAUTHORISED CHANGE OR MODIFICATION OR SETTING OF ROOM THERMOSTAT TEMPERATURE BELOW 60 F WILL MAKE WARRANTY NULL & VOID.</p>				
<p style="text-align: center;">POWER SUPPLY (SEE NOTES)</p>		<p>LEGEND</p> <ul style="list-style-type: none"> BLK - BLACK BLU - BLUE BRN - BROWN CCH - CRANK CASE HEATER COM - COMMON COMP - COMPRESSOR CC - COMP CONTACTOR FC - FAN MOTOR CAPACITOR FM - FAN MOTOR FMC - FAN MOTOR CONTACTOR HPS - HIGH PRESSURE SWITCH HTR - HEATER HVTB - HIGH VOLTAGE TERMINAL BLOCK L - LINE LPS - LOW PRESSURE SWITCH LVTB - LOW VOLTAGE TERMINAL BLOCK N - NEUTRAL NC - NORMALLY CLOSED NO - NORMALLY OPEN OPT - OPTIONAL PLP - PHASE LOSS PROTECTION PRI - PRIMARY RED - RED SEC - SECONDARY SW - SWITCH ON/OFF TDS - TIME DELAY SWITCH T,STAT - THERMOSTAT UVM - UNDER VOLTAGE MONITOR YEL - YELLOW WHT - WHITE <p>--- FIELD WIRING • TERMINAL / SPLICE ⊕ OPTIONAL MARKING ⊕ EARTHING</p>			
<p style="text-align: center;">POWER SUPPLY (SEE NOTE 7)</p>					
<p style="text-align: center;">POWER SUPPLY 208-230/220/240 V / 1PH.</p>		<p>NOTES</p> <ol style="list-style-type: none"> 1) ANY WIRE REPLACEMENT SHOULD BE OF 90°C TYPE OR EQUIVALENT AND COPPER CONDUCTOR ONLY. 2) POWER MUST BE SUPPLIED TO CRANK CASE HEATER FOR A MINIMUM OF 12 HOURS PRIOR TO START UP. IF THE POWER SUPPLY HAS BEEN INTERRUPTED FOR LONGER PERIOD THEN ASIAN CRANK CASE HEATER MUST BE ENERGIZED FOR A MINIMUM OF 12 HOURS BEFORE STARTING OF COMPRESSOR. 3) FUSED DISCONNECT SWITCH OR CIRCUIT BREAKER TO BE PROVIDED BY THE USER WITH RELEVANT RATINGS. 4) PLEASE ALLOW 2 TO 3 MINUTES BEFORE STARTING OF COMPRESSOR. 5) COMPRESSOR IS PROVIDED WITH INTERNAL OVERLOAD PROTECTION. 6) POWER CIRCUIT 1 - 208-230V/3PH/60Hz 7) POWER CIRCUIT 1 - 380-415V/3PH/50Hz WITH NEUTRAL 2 - 380-400V/3PH/60Hz WITH NEUTRAL 3 - 480V/3PH/60Hz WITH NEUTRAL 8) REFER INSTRUCTIONS WITH THE COMPONENTS FOR STAR / DELTA CONNECTIONS 9) IF THE POWER SUPPLY IS 230V, CONNECT TO L3 IF THE POWER SUPPLY IS 380V, CONNECT TO N 			
<p style="text-align: center;">CONTROL CIRCUIT PRIMARY 24 VOLTS</p>		<p>OPTIONS OPT. 1 - CRANK CASE HEATER</p>			
<p>FROM INDOOR UNIT 24V PRIMARY CONTROL SUPPLY</p>		<p style="text-align: right;">WR. 01A-00U-2C-4PM1P</p> <table border="1" style="width: 100%; border-collapse: collapse;"> <tr> <td style="width: 33%;">C240938</td> <td style="width: 33%;">1BC011L38</td> <td style="width: 33%; text-align: right;">00</td> </tr> </table>	C240938	1BC011L38	00
C240938	1BC011L38	00			

AUTHORISED DISTRIBUTORS



16 St, Abdelaziz Eissa Block 35
Ninth Region, Nasr City ,Egypt
Tel. :+2 02-2473-2550
E-mail : Info@ebaircondition.com



EBA



Tel: +973 1773 8333 | Fax: +973 1773 1541/1529
P.O. Box 15919, Manama, Kingdom of Bahrain
Email: export@awalgulf.com.bh | Website: www.awalgulf.com



8/5/2023

04/03/2021-01

* Certification varies from one product to another

